

PUMP SPECS SHEET

Model: CX 1515

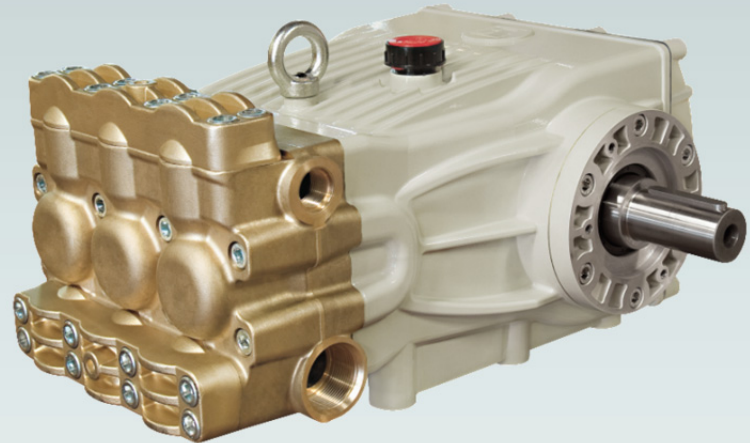

DATI TECNICI

SPECIFICATIONS

DIAMETRO PISTONE <i>PISTON DIAMETER</i>	40	mm
CORSA <i>STROKE</i>	44	mm
NUMERO PISTONI <i>NUMBER OF PISTONS</i>	3	
REGIME DI ROTAZIONE MASSIMO <i>MAX. SPEED</i>	1000	RPM
PRESSIONE MASSIMA <i>MAX. PRESSURE</i>	150	Bar
	2175	PSI
PORTATA A PRESSIONE MASSIMA <i>FLOW RATE AT MAX. PRESSURE</i>	153	l/min.
	40.3	GPM
PRESSIONE MINIMA IN ASPIRAZIONE <i>MIN. INLET PRESSURE</i>	-0.2	bar
	-3	PSI
PRESSIONE MASSIMA IN ASPIRAZIONE <i>MAX. INLET PRESSURE</i>	6	bar
	87	PSI
TEMPERATURA MASSIMA ACQUA IN ASPIRAZIONE <i>INLET WATER MAX. TEMPERATURE</i>	60	°C
	140	°F
POTENZA MASSIMA ASSORBITA <i>POWER REQUIREMENT</i>	44.9	kW
	60.2	HP
DIAMETRO ALBERO <i>SHAFT DIAMETER</i>	40	mm
DIAMETRO IN ASPIRAZIONE <i>SUCTION DIAMETER</i>	1" 1/2	BSP
DIAMETRO IN MANDATA <i>OUTLET DIAMETER</i>	1"	BSP
OLIO SAE 75W90 <i>CRANKCASE OIL SAE 75W90</i>	4	l
	1.05	U.S.G.
PESO <i>UNIT WEIGHT</i>	83.0	kg
	183	lbs

CARATTERISTICHE

FEATURES

- CARTER IN LEGA DI ALLUMINIO AD ALTA RESISTENZA
- *COMPACT DIE CAST ALUMINIUM CRANKCASE FOR HIGH STRENGTH*
- TESTATA STAMPATA IN OTTONE
- *FORGED BRASS HEAD*
- ALBERO A GOMITI IN ACCIAIO FORGIATO
- *FORGED STEEL CRANKSHAFT INCREASES LOAD RESISTANCE*
- CUSCINETTI A RULLI CONICI SOVRADIMENSIONATI
- *PREMIUM OVERSIZED TAPERED ROLLER BEARINGS*
- BIELLE IN LEGA DI BRONZO SPECIALE ANTIFRIZIONE
- *EXTRA-WIDE BRONZE CONNECTING RODS TO REDUCE FRICTION, HEAT, WEAR*
- GUIDE PISTONE IN ACCIAIO INOX A DOPPIO DIAMETRO
- *DOUBLE DIAMETER STAINLESS STEEL PLUNGER RODS*
- BOCCOLE AUTOLUBRIFICANTI IN PTFE
- *PATENTED DU-DRY PLUNGER ROD BUSHINGS PTFE COATED*
- PISTONI IN CERAMICA AD ELEVATA FINITURA SUPERFICIALE
- *HIGHLY POLISHED CERAMIC PISTONS*
- VALVOLE IN ACCIAIO INOX
- *EFFICIENT VOLUMETRIC STAINLESS STEEL CHECK VALVES*
- DOPPIA GUARNIZIONE A "V" AUTOLUBRIFICANTE IN ELASTOMERO RINFORZATO
- *DOUBLE "V" PACKING SELF-LUBRICATING SEALING SYSTEM IN ELASTOMER MAXIMIZES SEAL LIFE*

PUMP SPECS SHEET CX 1515

PUMP SPECS SHEET

CURVE DI PRESTAZIONI

PERFORMANCE CURVES

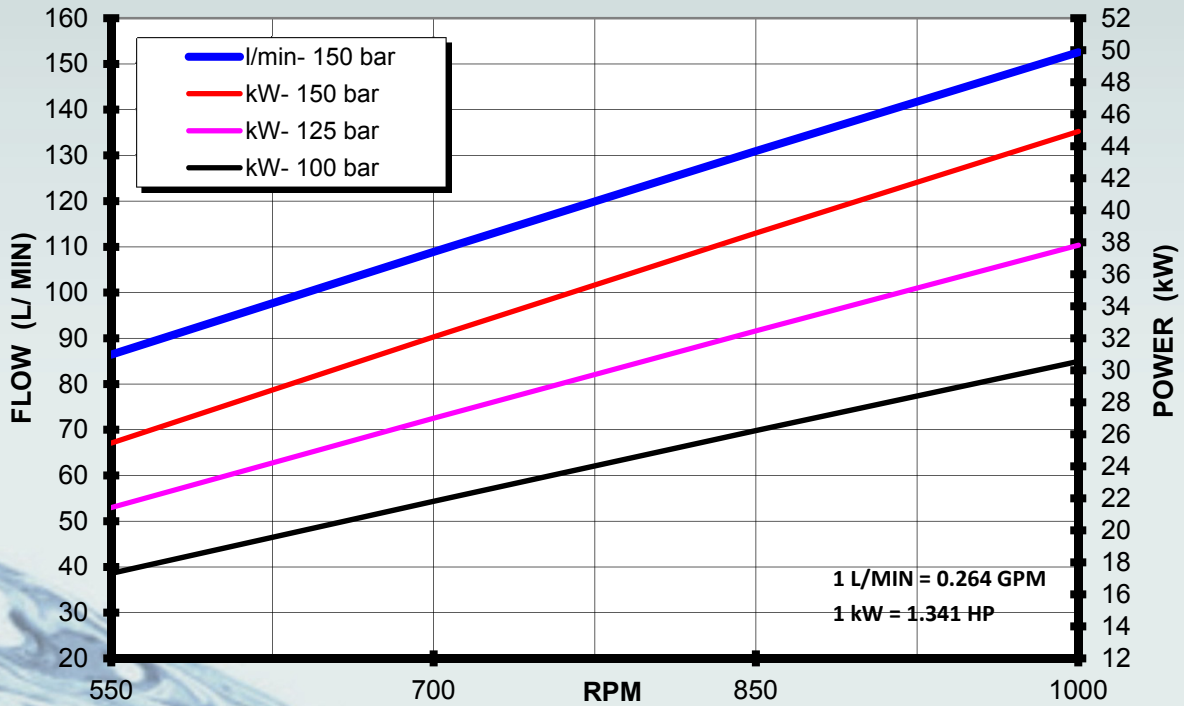

DIMENSIONI DI INGOMBRO

DIAGRAM DIMENSIONS

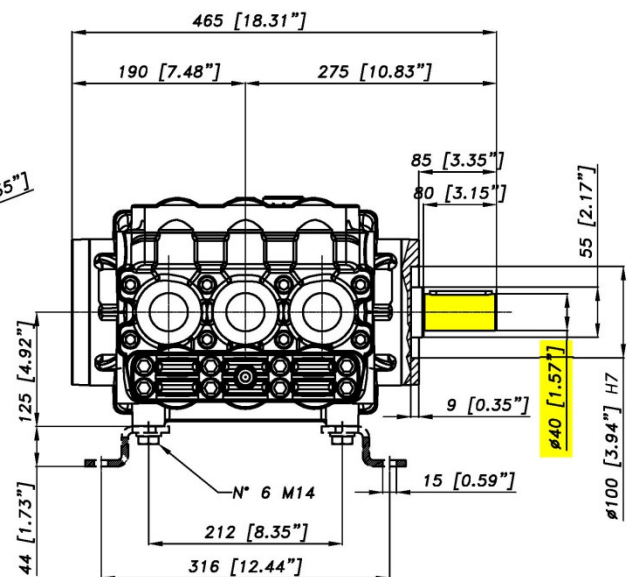
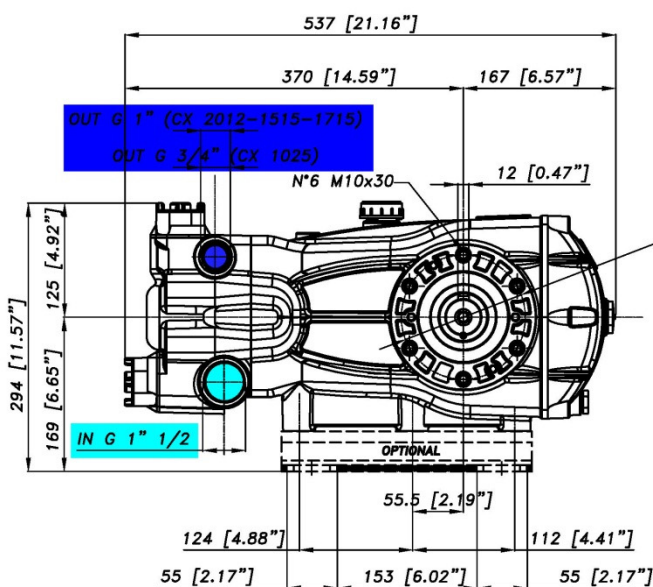

KIT PIEDINI COD. 74.9808.97.3 (OPTIONAL)
MOUNTING RAILS KIT P/N 74.9808.97.3 (OPTIONAL)

I dati riportati sono indicativi e non impegnativi, l'azienda si riserva di variarli in qualsiasi momento e senza alcun preavviso.
Due to our program of continuous product development, we reserve the right to alter specifications without notice.